

Verwerkingsvoorschrift

Kumax

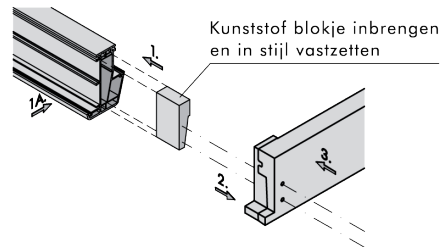
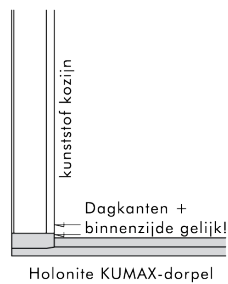
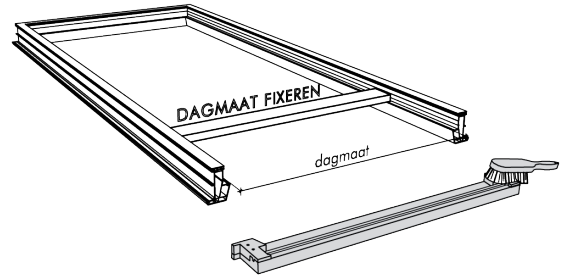
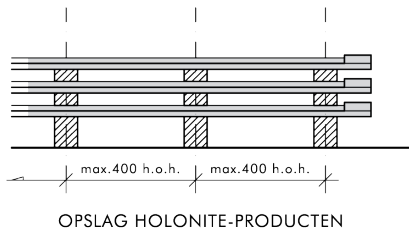

1A. Kunststof blokje vastzetten in stijl met schroef

Verbinden met zelftappende schroeven

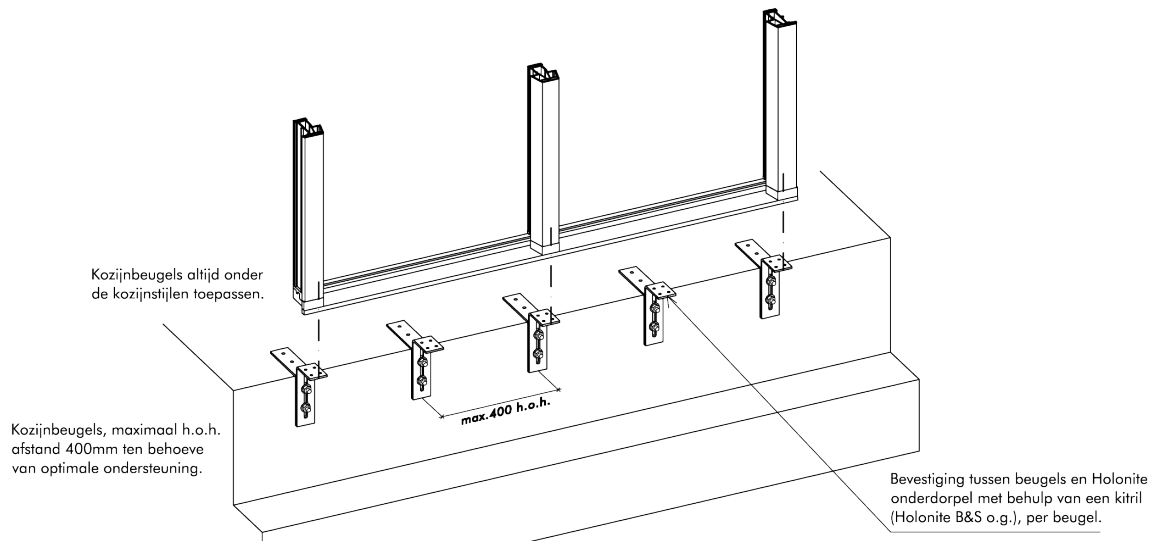

Verwerkingsvoorschrift

Kumax met manchet

