

# Verwerkingsvoorschrift

## Trimax

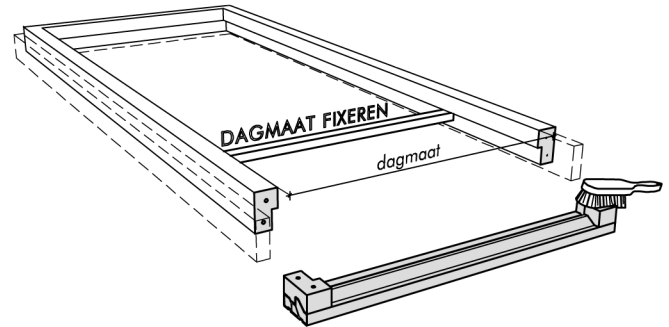

ALLE MANCHETTEN WORDEN GECOMPRIEERD VERWERKT (MET EEN TOLERANTIE VAN  $2 \pm 1$ MM). HOU DAAROM DE VERWERKINGSTIJD NA HET OPENEN VAN DE VERPAKKING IN DE GATEN.

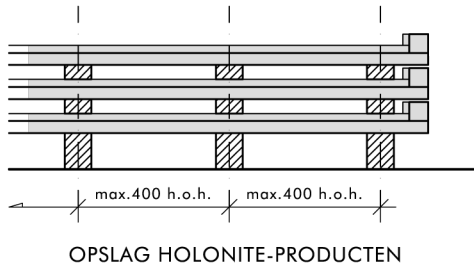
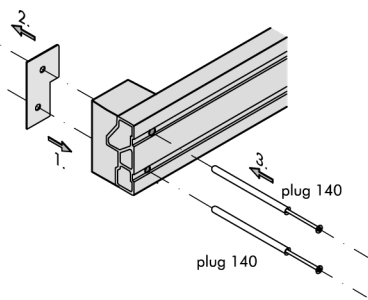
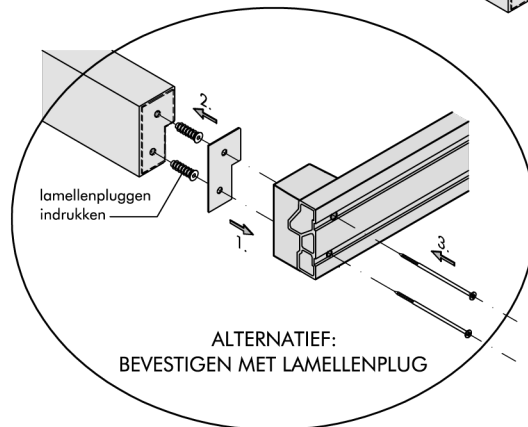
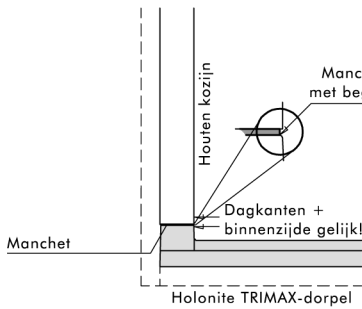

MAX. AANDRAAIMOMENT: 18Nm

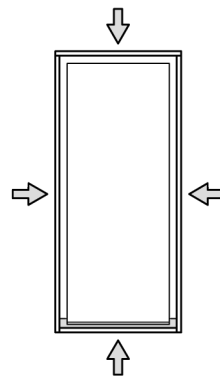

Vertikale en bovenste horizontale spouwlat in de spanning plaatsen.  
Onderste spouwlat afdoende verlijmen tegen Holonite trimax onderdorpel.

# Verwerkingsvoorschrift

## Trimax

